

rc2rotors Single Function Cyclic Mixer

The rc2rotors Single Function Cyclic Mixer is a sophisticated, state of the art, electronic mixing device for model helicopters. The primary purpose of this device is to enable the use of aileron and/or elevator axis gyroscopes on your CCPM equipped helicopter. The use of rotor head gyroscopes offers fantastic active stabilization that can dramatically improve the flight characteristics in the absence of a stabilizing flybar.

The mixer configuration settings may be changed at any time, simply by altering a setting in the configuration menu. The configuration menu is accessed via a detachable display module which is removed before flight. The display module contains a backlit 2 line by 16 character LCD and 4 pushbuttons. With easy to use menus, it is both quick and convenient to configure the Multi-Mixer on the workbench and at the flying field for maximum flexibility.

The Single Function Cyclic Mixer supports the following features:

- Servo configurations supported: 3-servo 120 CCPM, 3-servo standard, 3-servo 90 CCPM, 4-servo 90 CCPM.
- Electronic phasing: -45 to +45 degree phasing in 1 degree increments.
- 16-bit servo input and output resolution for exceptionally smooth response.
- Servo Reverse for each servo.
- Sense Reverse for pitch and roll axis controls.
- Digital Servo Centering Trim Adjustment for each servo.
- Control Axis Trim Adjustment for the pitch, roll, and collective pitch.
- Supports both analog and digital servos.
- Compatible with most gyros.

The following sections describe how to physically connect the Multi-Mixer to the radio equipment in your model helicopter and how to properly configure the various options.

Making the Physical Connections

The Single Function Cyclic Mixer has 3 separate input leads connected to it. With the mixer oriented such that the pins on the mixer are facing up, the servo wire closest to the top is Lead #1, the middle wire is Lead #2, and the bottom wire is Lead #3. Lead #1 connects to the roll (aileron) channel. Lead #2 connects to the pitch (elevator) channel. Lead #3 connects to the collective pitch channel.

If rotor head gyros are to be used, the gyros are connected directly to the receiver, and the appropriate mixer input lead connects to the given gyro for that axis. Rotor head gyros are typically placed on the pitch and roll axis. If choosing to use only a single rotor head gyro, maximum effect is obtained when the gyro is placed on the pitch axis. Using an additional gyro for the roll axis helps improve stability even further.

Power is provided to the mixer through each of the 3 input leads. The mixer regulates voltage for itself and provides full unregulated voltage directly to the servos.

The Single Function Cyclic Mixer has 4 rows of header pins which are used to connect to the individual servo leads. Servos are connected to the Multi-Mixer such that the signal lead (orange or white) is closest to the outer edge. Power (red) is the middle pin. Ground (brown or black) is the inner pin.

The Single Function Cyclic Mixer operates up to 4 servos which are referred to with the names S1, S2, S3 and S4. With the header pins on the right hand side, the rows of pins correspond to S1, S2, S3,

and S4, where S1 corresponds to the bottom row of pins and S4 corresponds to the top row of pins. See figure 1.

A 3-servo configuration will use S1, S2, and S3 only. A 4-servo configuration will make use of S1, S2, S3, and S4.

In a 3-servo standard washplate configuration, S1 connects to the roll axis servo, S2 connects to the collective pitch servo, and S3 connects to the elevator servo. In a 3-servo 90 or 120 CCPM configuration, S1 and S2 connect to the opposing roll axis servos, and S3 connects to the pitch axis (elevator) servo. In a 4-servo 90 CCPM configuration, S4 connects to the opposing pitch axis servo to complement S3.

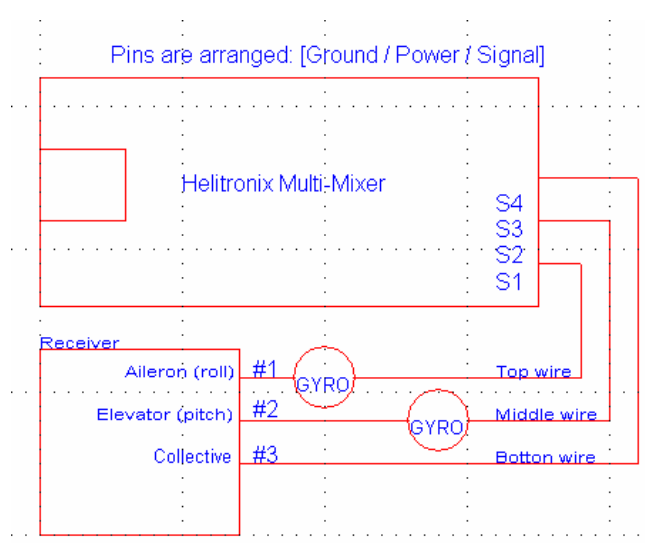

Figure 1 - Schematic Diagram of Receiver Connections

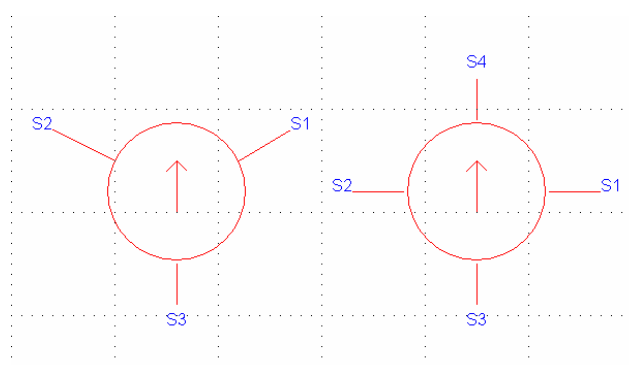

Figure 2 - Servo layout for 3 and 4 servo CCPM washplate configuration

Configuring the Single Function Cyclic Mixer

The mixer includes a display module with 4 integrated pushbutton switches. These switches are silk screened with labels S1 through S4. S1 and S2 are used to move up or down through the configuration menu. S3 and S4 are used to increase or decrease a value, or toggle a configuration setting.

To configure the mixer, begin by connecting the interface cable to the display module and the mixer. There is an RJ-45 connector on each device for this purpose. After applying power, the display unit will print "Single Function Cyclic Mixer". This message will display for 2 seconds followed by "rc2rotors" for 2 seconds. The mixer will then display the first menu option, which is the swashplate mode configuration item.

The mixer employs a mechanism to prevent accidental changes to the configuration settings. The ability to make a change to a setting is disabled, or locked out, by default. In order to make a change, it is necessary to "unlock" the specific setting by simultaneously pressing S3 and S4, and then releasing these two buttons. Notice that the mixer displays a "lock" icon in the upper right hand corner of the display when an option is locked. After releasing S3 and S4, the option will become unlocked, and the lock icon will disappear. Once unlocked, S3 and S4 may be used to change the given configuration value accordingly. As soon as either S1 or S2 are used to move to the next item in the menu, the configuration for that item is locked automatically again. This feature makes it more difficult to make unintended changes to the configuration.

The Single Function Cyclic Mixer menu is structured in the following order:

Swashplate – Use this option to configure the swashplate control type. Choose from 3-servo standard, 3-servo 120 CCPM, or 4-servo 90 CCPM. Note that 3-servo 90 CCPM uses the 4-servo 90 CCPM configuration because these two modes are electrically identical. For 3-servo 90 CCPM, choose the 4-servo 90 CCPM setting.

Phasing – Use this option to configure the rotor head phasing (timing). Phasing may be set from -45 to +45 degrees. These settings will enable the proper phasing for all rotor heads. In general, a 2-bladed head uses 0 degrees phasing, and multi-bladed heads (3 or more blades) use +45 or -45 degrees phasing. Please consult your rotor head instructions for the proper phase angle. See the section "Rotor Head Phasing" for additional details. The ability to change the phasing in 1 degree increments is a convenience feature so that fine adjustments may be done electronically, rather than by rotating the swashplate lock.

Servo Reverse S1 through S4 – Use this option to reverse the rotation of any given servo. Choose from normal and reverse. In general, it is easiest to use these servo reverse settings to ensure that all servos (for a CCPM configuration) move the swashplate in the same direction (and in the correct direction) when given a collective pitch input. Reverse any servo that moves the swashplate the wrong way. Reverse the direction of all servos if it is necessary to change the direction of swashplate movement in response to the stick movement. Or, change the direction of movement using your transmitter, whichever is more convenient.

Aileron Sense – Use this option to change the direction of the aileron (roll) axis input.

Elevator Sense – Use this option to change the direction of the elevator (pitch) axis input.

Servo Offset S1 through S4 – Use this option to center a given servo. The servo may be trimmed anywhere from -100 to +100 steps. The servo centering is important for CCPM configurations to ensure optimal control rod geometry. In general, we look for servos arms to be mounted horizontally at 90 degree angles at the center collective pitch, neutral cyclic stick setting.

C. Pitch Trim – Use this option to configure the collective pitch trim.

Elevator Trim – Use this option to configure the elevator trim.

Aileron Trim – Use this option to configure the aileron trim.

Transmitter Setup

To properly configure the transmitter, you must enable the transmitter's STANDARD SWASH PLATE, NON-CCPM control type. This mode is used to output one discreet channel for aileron, one discreet channel for elevator, and one discreet channel for collective pitch. You do not and cannot use any CCPM function in your radio with this mixer.

It is recommended that during the initial setup, gyros should not be connected to the mixer. This is simply to avoid confusion during the setup phase should a gyro be reversed. Once the transmitter and the mixer have been configured, the gyros can be added in and gyro orientation can be established.

Use any ATV setting that you wish to achieve the desired servo travel. For CCPM systems this value is usually 60% for the aileron, elevator and collective pitch channels.

Rotor Head Phasing

Adjusting the rotor head phasing (or timing) from 0 degrees is a necessary procedure for those helicopters with multi-bladed rotor heads. This feature should only be enabled after all the servos are going in the correct direction.

In general, a 2-bladed head uses 0 degrees phasing, and multi-bladed heads (3 or more blades) use +45 or -45 degrees phasing.

First identify one of the setup conditions outlined below as appropriate for your mechanical configuration. The descriptions below assume that the rotor head is viewed from the top down, while you stand behind the helicopter. For configurations not listed here, consult the rotor head setup diagrams.

- Right hand rotation head, controlling the leading edge of the rotor blade. The phasing adjustment is correct when the front of the swash tilts forward and to the left at the 11 o'clock position when forward cyclic is applied.
- Left hand rotation head, controlling the leading edge of the rotor blade. The phasing adjustment is correct when the front of the swash tilts forward and to the right to the 2 o'clock position when forward cyclic is applied.

After you have set the desired phase angle for the given rotor head, place any blade parallel over the tail boom, and give a fore and aft cyclic movement. This blade should not move, or barely move at all. Any large blade movement observed indicates that the phase angle needs adjustment. A correction can be made either mechanically by adjusting the position of the swashplate lock or electronically by adjusting the phase angle value stored in the mixer. When the system is properly setup, the rods going from the inner ring of the swash plate to the blade grips are as parallel as possible to the main shaft.

Gyro Setup

When using gyroscopes with this device, you must setup the gyroscopes with the same care that is exercised when configuring the device for a tail rotor. You must pay absolute attention to the mounting position of the gyro, so that a rotation of the gyro causes the swashplate to move in the correct direction. For example, rotating the aileron axis gyro to the right should generate a swashplate deflection to the left. A rotation of the gyro in the elevator axis must cause the swash plate to tilt in the opposite direction. Failure to setup the gyro correctly will absolutely make the helicopter uncontrollable. Triple check the gyro mounting before your test flight!

Some gyros feature a remote gain adjustment. If you have the available channels, wire these into separate receiver channels. If you do not have enough channels available, use a Y-harness to hook them together to a single channel. Gain for both gyros will then be set together, and to the same value in this case.

It is recommended that you use approximately 5-10% of the gyro gain for initial setup and test flying. Very little gain is required to make huge flight improvements. The basic idea is to start with a low gyro gain setting and then sneak up on the correct value. It is better to start too low than it is to start too high. If the gain is setup too high, the rotor head will oscillate, or hunt, just like the tail rotor would under the same circumstances. This oscillation could destroy your helicopter if the magnitude is too large. Therefore, it is imperative that you start with a low gain in order to avoid a large gyro induced oscillation. As you increase the gain during the test flights, the helicopter will become more stable in that axis. Eventually as the gain is increased, you will find a gain setting that causes the helicopter to oscillate slightly. You want to reduce the gain from this setting so that the oscillation stops. Choose a gain setting that feels comfortable to you. You do not have to choose the highest gain setting possible.

If your gyros do not feature remote gain adjustment, make sure the potentiometers on the gyros are accessible for the initial test flights.

Battery Care

Current draw of the rc2rotors Single Function Cyclic Mixer is under 50mA without the display module connected. While the load of the mixer itself is low, the use of additional gyroscopes in your system will increase the load of the system dramatically because of the additional servo movement a gyro creates. Pay careful attention to the condition of your batteries each flight. The best case would be to charge your batteries between each flight. It's not strictly necessary, but there's no downside to having a fully charged battery pack running all of the electronics. We use and recommend a minimum 2400mAh capacity battery pack.

While exercising the servos in the model with the display unit connected, you might notice that the backlight turns off. This would occur if the voltage dips below 5.0v. If this occurs with a charged battery, use this as a warning sign that your flight battery needs to be replaced. If the backlight turns off due to this low voltage situation, the special "lock" icon will disappear and will be replaced by a "v" character instead. This does not indicate a malfunction. It simply means that the display module lost power momentarily. Be sure to charge your battery if this happens.

Warranty Information / Crash Damage Checkup

All rc2rotors products come with a 30-day money back guarantee. If you are unsatisfied with your purchase for any reason, return the undamaged item to rc2rotors within 30 days of purchase, and we will refund your money excluding shipping.

Should your helicopter crash for any reason, and you desire a checkup of the rc2rotors Single Function Cyclic Mixer, simply return it to us for a free checkup. The checkup will be free of charge, but we do require that you pay the shipping both ways.

The rc2rotors Single Function Cyclic Mixer has a one year warranty from time of purchase that covers manufacturing defects only. That is, if you physically damage the unit from a crash, the warranty does not cover this. We expect the mixer to provide years of trouble free service. If your device should prove defective as outlined above within the first year, Helitronix will repair or replace the unit at our option. Please provide a copy of your sales receipt for warranty purposes. Buyer pays for shipping to rc2rotors. If the unit is found to be defective, we will return the repaired/replaced unit free of charge. If the unit is not found to be defective, the buyer pays shipping charges.

For service, return units with a note explaining the service you are requesting, your phone number, and a return address to:

rc2rotors,
Park Cottage,
Parkgate Lane,
Brompton-on-Swale,
Richmond,
North Yorkshire.
DL10 7HA
United Kingdom.

email rich@rc2rotors.co.uk

Frequently Asked Questions about the rc2rotors Single Function Cyclic Mixer

Q1: The LCD module blanked out and shows a cursor with no other text. What happened?

A: The battery voltage dropped below 5.0v and the display reset. If you press S1 or S2, the mixer will send some text to the display.

The display module needs 5.0v volts in order to operate properly. If the voltage drops below 5.0v, the display will reset. The mixer itself will continue to operate. A good condition battery will easily maintain a voltage higher than 5.0v under load. If you find that your display is resetting under load even with a charged battery, that means your battery is not in good health and should be replaced.

Q2: The LCD module shows a \ instead of a lock icon. What happened?

A: The battery voltage dropped below 5.0 and the display reset. After the reset, the mixer displayed some text, either because it was in the middle of writing to the display, or because you pressed on of the menu buttons. The \ character is displayed instead of the lock icon because the special lock icon was erased during the LCD reset. It has been replaced by a default character, which happens to be the \ that you see. Refer to Q1 for additional details on what is happening and why.

Q3: Which cable on the mixer connects to the aileron, elevator, collective pitch, rudder channel?

A: On the Single Function Cyclic Mixer there are 3 cables that exit the mixer, one on top of another. With the pins facing up the top wire connects to the aileron input, the next wire (middle) connects to the elevator input, and the last wire (bottom) connects to the collective pitch input. On the Multi-function Cyclic Mixer, there is a 4th wire. This 4th wire is on the bottom of the stack, and this connects to the rudder channel.

Q4: Can I hook a battery up to the unused pins?

A: Yes. All the rows of pins share a common ground and power. You may connect a battery to any unused row of pins. You would do this if you wanted to augment your radio receiver battery with another battery to make sure that your battery voltage stays at a safe level under load.

Q5: Tell me more about elevator mixing.

A: Elevator mixer is available on the Multi-function Cyclic Mixer only, and it is used only for the tandem and configuration. The elevator mixing function adds elevator tilt forward and backward in response to the elevator stick movement. It is used to supplement the use of differential collective pitch (DCP) for those applications that require it. A tandem rotor helicopter does not require elevator mixing in order to fly well. It is available as an option should you want it.

Q6: What gyro should I use?

A: The Futaba GY-401 works very well, as does the Futaba Multi-Axis GY352 and the CSM-180. The Futaba GY-240 doesn't work well as a rotor head gyro in some instances, so you would need to experiment with it more if you wanted to make that particular gyro work. Generally, the gyros are not put into heading hold, but you can do that if you want to. Rate mode is used by the overwhelming majority of pilots when used on the rotor head this way.

Q7: What gain setting should I use for the rotor head gyro?

A: The actual gain setting depends on your model and the gyro itself. Low gain values are normal. For example, the gain for a GY-401 when used on the elevator might be 22-28%. The gain for a CSM-180 when used on the elevator might be 17%. The aileron axis is less sensitive, and higher gains can be used. You need to start with a low gain and then incrementally increase the gain until the rotor head behaves the way you like it. You do not want to start too high or else a gyro induced oscillation will occur which could destroy your helicopter. That makes for a bad day, so don't do that. You've been warned.

Q8: Can I use heading hold mode?

A: Yes. It works fine. However, you might not like how it feels. Try it out, but think about how the controls will feel different before you engage in this exercise. Most of us use the gyros in non-heading hold mode.

Q9: What size battery should I use?

A: We use 2400mAH size batteries (or larger) and charge before every flight. Use a larger battery if your servos will draw more power than average. For example, a 2400mAH battery drives a helicopter with 3 gyros, and 5 digital servos for 15 minutes without any problems. We still charge after every flight!

Q10: Do I need to charge my battery before every flight?

A: If having control over your helicopter is important to you, then we strongly advise you take great care of your batteries and make sure that they are up to the task that you have put them to. There is no downside to charging before every flight.

Q11: Can I fly with the display module connected?

A: Yes. However, it does draw extra power from the receiver battery (about 100mA).

Q12: I connected the display module to the mixer but I can't change the options. The mixer ignores some or all of my button presses on the display unit. How do I fix this?

A: You must connect all three leads from the mixer to your receiver. The receiver and transmitter must be powered so that the receiver sends valid signals to the mixer. It is not enough to plug in only one or two of the three leads